



GS100P WEIGHING CONTROLLER

Setup Manual

CONTENTS

1 - Introduction	1
2 - General Information	2
3 - Casing & Display	5
4 - Wiring	10
5 - Setup & Calibration	16
6 - Setpoint Setup	38
7 - Factory Analog Output Cal	45
8 - Setpoint Easy Access	47
9 - Reset PIN Numbers	48

APPENDICES

A - Tare & Batch Features	49
B - Input Functions	53
C - Zero Maintenance	56
D - Serial Register Tables	58

1 INTRODUCTION

The GS100P controller interfaces smoothly with a wide range of PLC and monitoring systems. It is designed to relieve the PLC of processing overhead, reduce costs and extend the capability of the total system.

The GS100P is straightforward to use, and has a built-in alphanumeric LED display and five front-panel buttons. Designed specifically for use in weighing applications, the GS100P comes factory pre-calibrated to suit either a 4-wire or a 6-wire strain gauge input. Setup (or re-calibration) is simple, with on-screen, step-by-step instructions.

This sophisticated instrument features output and input isolation, eliminating the need for any special consideration when interfacing to analog/serial inputs, or PC's/PLC's/HMI's. The GS100P can be customised to include a serial port and an analog output. Up to four relay outputs can also be added.

2

GENERAL INFORMATION

2.1

Model codes

GS100 SERIES MODEL CODES

GS100	Gedge Series
P	Panel mount
- LV	15-48V AC / 10-72V DC power supply
- HV	85-265V AC / 95-370V DC power supply
- R	Relay outputs (4) form A
- 2	RS232 isolated output
- 4	RS485 isolated output
- A	Analog output option installed

OPTIONS (AS SPARE PARTS)

GS - R	Relay outputs (4) form A
GS - 2	RS232 isolated serial output
GS - 4	RS485 isolated serial output
GS - A	Analog isolated source powered output (4-20mA, 0-10 V)

2.2 Specifications

Input	4/6-wire strain gauge, 1-5mV/V
Power supply	HV 85-265V AC/95-370V DC or LV 15-48V AC/10-72V DC
Power (max)	5W, fully optioned, 8 loadcells
Easy setup	Intuitive text prompts for easy setup.
Calibration	Pre-calibrated for 0-10,000 counts (2mV/V sensor gain at full scale). Can be recalibrated using the auto (apply mass) or mV/V method. Adjustable zero offset.
Security	Calibration and setpoint functions have independent security code access. Setpoint functions are independently configurable, and accessible through the F2 key.
Excitation	5V DC excitation supplied (powers up to 8 x 350Ω loadcells).

Sampling rate	Up to 50Hz
Resolution	18-bit
Accuracy	0.005% of reading
Temp. drift	Typically 3ppm/°C

OPTIONAL OUTPUTS

Analog output	Isolated 16-bit 4-20mA/0-10V output (fully scaleable). 7 updates/sec. Window programmable over any range within the full-scale range of the controller
Serial port	Isolated GS option 2 or 4 <i>Modes:</i> ASCII, Modbus RTU slave, Ranger A output (5 updates/sec). <i>Data rates:</i> 300-38400. Odd, even or no parity.
Relay outputs	4 x 5A Form A relays

3 CASING & DISPLAY

3.1 Case dimensions

Dimensions 48 x 96 x 119.5mm (H x W x D)

Panel cutout 45.5 x 92.5mm (H x W)

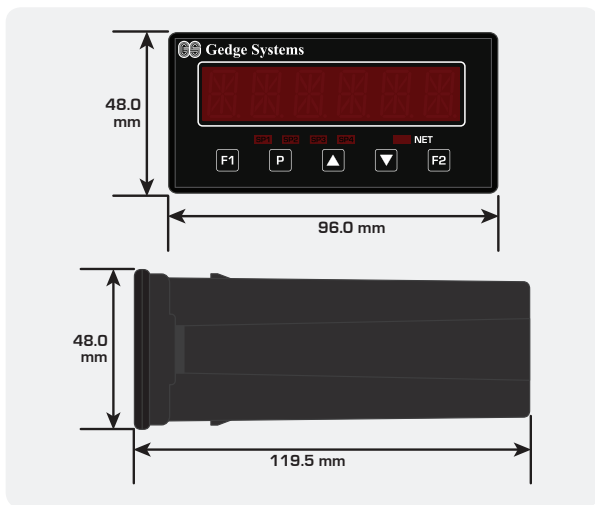

3.2 Front panel

The GS100P has a 6-digit, 14-segment alphanumeric LED display and five front-panel buttons. It also includes four setpoint annunciator LED's and one NET annunciator.

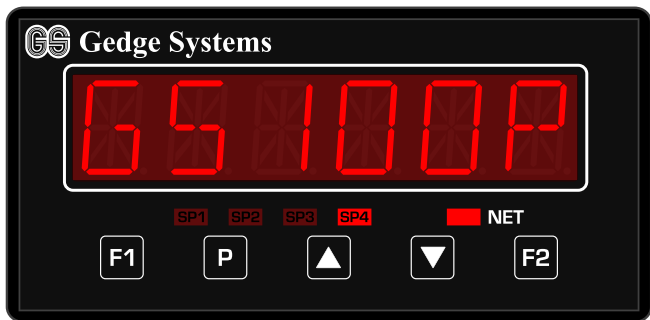

SPX The setpoint LED's are used to indicate active setpoints.





NET The net LED is indicates when the net value is being displayed, and is used for the **FLASH GROSS** function, which toggles between net and gross values. (See 5.2L)

- F1** This button is used to access the **input setup and calibration** menu. See section 5.
- P** This button is typically used to save your settings and advance to the next step in the setup process. The function of a single keypress of this button from the operational display can be user programmed - see 5.2H.
- ▲** This button is typically used to scroll through options or increase values in the setup menu. Pressing this button from the main display will allow you to view/reset the peak value and view the mV value of the input [see 3.3].
- ▼** This button is typically used to scroll through options or decrease values in the setup menu. Pressing this button from the main display will allow you to view/reset the valley value [see 3.3].
- F2** This button is used to access the **setpoint setup** menu [see section 6] and the **setpoint easy access** menu [see section 8].



3.3 Display shortcuts (view mode)

Press  at any time to return to the main display.



 Used to view/reset the **PEAK** value and to view the input value in mV.



- Press the  button once from the main display. **PEAK** appears and toggles with the maximum measured weight value since the instrument was turned on (or reset). To reset **PEAK**, press both the  and  buttons together now.
- Press the  button again. **MV** appears and toggles with the current value of the input signal in mV.

 Used to view/reset the **VALLEY** value.

- Press the  button once from the main display. **VALLEY** appears and toggles with the minimum measured weight value since the instrument was turned on (or reset). To reset **VALLEY**, press both the  and  buttons together now.

3.4 Display brightness

- A Press the  and  buttons together from the operational display. **BRI** appears on the display and toggles with the current brightness setting.

- B Use the  and  buttons to adjust the brightness of the LED backlight as required, and then press . The display returns to normal operating mode.

4 WIRING

4.1 Pinouts

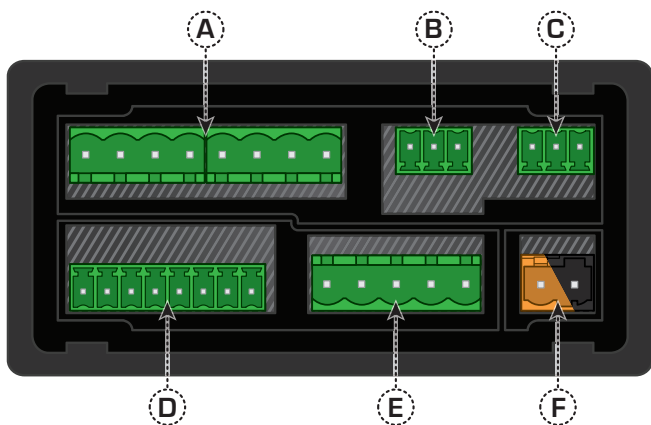

(A) 4 x relays [see 4.5] **(D)** Loadcell input [see 4.3]

(B) Serial port [see 4.6] **(E)** Function pins [see 4.7]

(C) Analog output [see 4.4] **(F)** Power supply [see 4.2]

4.2 Power supply

(see 4.1F)

Before you begin, determine whether your controller is configured for low or high voltage power supply. Check the label on the unit against the colour of the connector:

- **Orange** = high voltage (85-265V AC, 95-370V DC)
- **Black** = low voltage (15-48V AC, 10-72V DC)

REMEMBER TO SWITCH YOUR POWER SUPPLY OFF BEFORE YOU BEGIN WIRING. NEVER CONNECT YOUR LOW VOLTAGE CONTROLLER TO MAINS POWER.

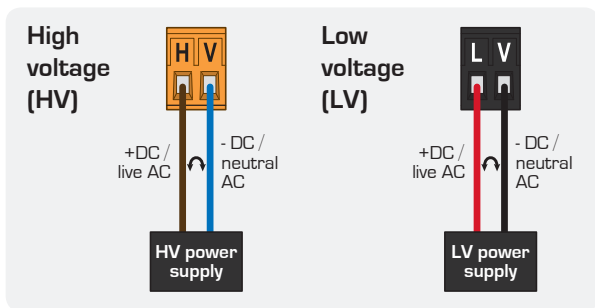

4.3 Loadcell input module

(see 4.1D)

Wire your loadcell input module as shown in the diagram.

This input module is pre-calibrated for 0-10,000 counts full scale with a 2.000mV/V load cell sensor.

YOU MAY CONNECT MULTIPLE LOADCELLS IN PARALLEL, OR USE A LOADCELL FIELD JUNCTION BOX (GKJB6-7T5).

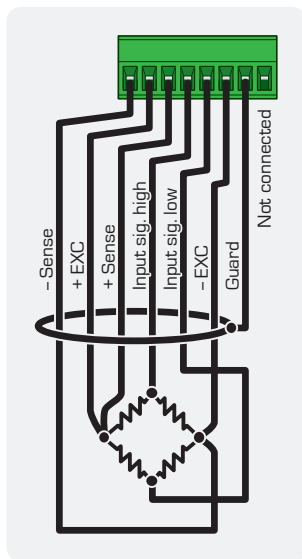

4.4 Analog output (if fitted)

(see 4.1C)

If your controller has analog output fitted, wire it as shown.

If you do not have analog output fitted then skip this step.



4.5 Relays (if fitted)

(see 4.1A)

If your controller has relays fitted, wire them as shown. Relays can be programmed to operate within the total span range of the controller.

If you do not have relays fitted then skip this step.

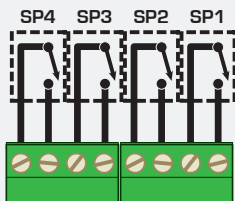

4.6 Serial port (if fitted)

(see 4.1B)

If your GS100P has a serial port fitted, wire it as per the appropriate diagram.

If you do not have a serial port fitted then skip this step.

Option 2



Option 4



4.7 Function pins (if required)

(see 4.1E)

Connect switches as required between the function pins.

Pin functions are user configurable, and can be set up in 5.2I-K.

See Appendix B for a list of input functions.

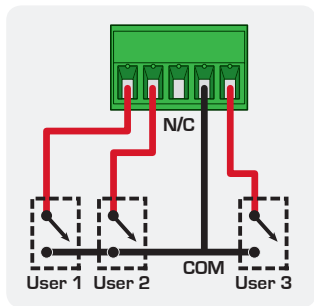

4.8 Power up

Once you have completed the wiring process it is safe to switch on your power supply. Ensure that your display is functioning before you proceed.

5 SETUP & CALIBRATION

Enter the calibration mode by pressing **F1**.

5.1 Enter calibration PIN

A **__ _ ENTER CAL PIN** scrolls across the display and toggles with **0**. Use the **▲** and **▼** buttons to enter your security code (factory default 1). Then press **P**. If the correct PIN is entered then the setup is started at 5.2.



If an incorrect PIN number is entered, **__ _ ACCESS DENIED** scrolls across the display and it returns to the normal operating mode.

YOU WILL BE GIVEN THE OPPORTUNITY TO CHANGE YOUR PIN NUMBER AT THE END OF THIS SECTION (5.8). IF YOU HAVE FORGOTTEN YOUR PIN NUMBER, SEE SECTION 9.

5.2 Input setup

- A** ___ **INPUT SETUP** scrolls across the display and toggles with **SKIP**. Press **[P]** to skip to 5.3, or the **[▲]** button and then **[P]** to **ENTER** input setup.
- B** ___ **SAMPLING RATE** scrolls across the display and toggles with the selection. Use the **[▲]** and **[▼]** buttons to select: **1HZ**, **10HZ** (default) or **50HZ**. Press **[P]**.
- C** ___ **DECIMAL POINT POSITION** scrolls across the display and toggles with the current selection. Using the **[▲]** and **[▼]** buttons, select: **NO DP**, **0.0**, **0.00**, **0.000** or **0.0000**. Then press **[P]**.
- D** ___ **ROUNDING** scrolls across the display and toggles with the current display rounding. Use the **[▲]** and **[▼]** buttons to select: **NONE**, **2**, **5** or **10**. Then press **[P]**.

*Rounding is quoted in display counts and is not influenced by decimal point position. (Eg. If your input signal is 5.3, the display will show: 5.3 at **NONE**, 5.4 at **2**, 5.5 at **5**, or 5.0 at **10**).*



- E** ___ **MODE** scrolls across the display and toggles with the current weighing mode. Use the  and  buttons to select **NORMAL** (default) or **BATCH**, and press .

*In **NORMAL** (default) mode the controller displays the gross or net weight on the display, and does not perform any batch calculations.*











*In **BATCH** mode the controller displays batch or gross weight, and SP 1 and SP 2 function as dedicated batch control setpoints. Refer to Appendix A.2 for additional information.*



- F**  **If you selected NORMAL in 5.2E:**



Skip step 5.2G and continue to 5.2H now.

- G** ___ **BATCHING DIRECTION** scrolls across the display and toggles with current selection. Use the  and  buttons to select either: **NEG** (negative, for emptying operations) or **POS** (positive, for filling operations). Then press .

Refer to Appendix A.2 for additional information.

- H** _ _ _ **PROG BUTTON** scrolls across the display and toggles with the current selection. Use the  and  buttons to select a function¹ to be performed when the  button is pressed from the operational display: **HOLD, TARE/BATCH², ZERO, PEAK, PK RST** or **PRINT**. Then press .
- I** _ _ _ **USER INPUT1** scrolls across the display and toggles with the current selection. Use the  and  buttons to select a function¹ to be performed when the User 1 input pin³ at the rear of the meter is activated: **LOCK, TARE/BATCH², ZERO, PEAK, PK RST** or **PRINT**. Then press .
- J** _ _ _ **USER INPUT2** scrolls across the display and toggles with the current selection. Use the  and  buttons to select a function¹ to be performed when the User 2 input pin³ at the rear of the meter is activated: **HOLD, TARE/BATCH², ZERO, PEAK, PK RST** or **PRINT**. Then press .

K _ _ _ **USER INPUT3** scrolls across the display and toggles with the current selection. Use the  and  buttons to select a function¹ to be performed when the User 3 input pin³ at the rear of the meter is activated: **TARE/BATCH**², **ZERO**, **PEAK**, **PK RST** or **PRINT**. Then press .

L _ _ _ **FLASH GROSS** scrolls across the display and toggles with the currently selected setting. Using the  and  buttons, select **NO** or **YES**. Press .

This will cause the display to toggle between the Net/Gross values for 3 seconds each. Toggling will only occur if the controller has been tared and the Net/Gross values are different. The NET LED indicates which value is being displayed (On: Net, Off: Gross). This option will be disabled if a batch is currently in progress.

-
- 1 For more information on available functions, see Appendix B.
 - 2 **TARE/BATCH** options are subject to the weighing mode selected in 5.2E above. (**NORMAL** mode = **TARE** option, **BATCH** mode = **BATCH** option.) See Appendix A for more information.
 - 3 See 4.7 to wire rear input pins.

5.3 Calibration

- A** **___ CALIBRATION TECHNIQUE** scrolls across the display and toggles with **SKIP**. Press **[P]** to skip to 5.4, or use the **[▲]** and **[▼]** buttons to select: **AUTO**, **MV/V**, **ZERO** or **E_CAL**. Then press **[P]**.

Your GS100P is factory pre-calibrated for 0-10,000 counts (2mV/V sensor gain at full scale).

AUTO - Uses zero and span values to calculate the scale and offset. This is the most accurate calibration method, but requires known low and high input signals, usually supplied by test weights. There are separate zero and span calibration procedures, so you do not have to perform both at the same time.

MV/V - Uses values from the load cell manufacturer's test certificate, making it ideal for silo and tank applications.

ZERO - Allows manual adjustment of the calibrated zero offset.

E_CAL - Allows the user to view and edit the electronic calibration values (zero offset and scale factor). These two values are updated when any calibration is performed. Noting these values and entering them into another instrument will copy the calibration. You may also 'trim' these values to alter the current calibration.

B The step that you proceed to now will depend on your selection in **5.3A**.

AUTO: Complete steps 5.3C-I



MV/V: Complete steps 5.3J-M

ZERO: Complete steps 5.3N-O

E_CAL: Complete steps 5.3P-R

Please note that following calibration you will be automatically directed back to the operational display. To enter step 5.4, you must select **SKIP** at 5.3.

▶▶ AUTO CALIBRATION METHOD ▶▶



C ___ **CALIBRATE ZERO** scrolls across the display and toggles with the current selection. Use the  and  buttons to select **NO** or **YES**, and then press .



D



If you selected NO in 5.3C:

Skip step 5.3E and continue to 5.3F now.

E ___ **REMOVE WEIGHT - PRESS P TO ACCEPT** scrolls across the display and toggles with the current no-load value. Remove the weight. Use the  and  buttons to adjust the no-load value if required. Then press .

F ___ **CALIBRATE SPAN** scrolls across the display and toggles with the current selection. Use the  and  buttons to select **NO** or **YES**, and then press .



G



If you selected **NO** in 5.3F:

Skip step 5.3H and continue to 5.3I now.



H **___ ADD CAL WEIGHT - ENTER DESIRED SPAN -**

PRESS P TO ACCEPT scrolls across the display and toggles with the current span value. Apply a calibration weight to the weigh platform. Then use the  and  buttons to adjust the value, and press  to accept.



I If **AUTO** calibration was successful, you will be directed out of the calibration menu to the operational display without viewing any further scrolling messages.



If calibration fails, **___ CALIBRATION FAILED** will scroll across the display twice and you will be directed out of the calibration menu to the operational display. Check your signal and connections, and then repeat the calibration procedure.

▶▶ MV/V METHOD ▶▶

- J** **___ ENTER TOTAL FULL SCALE WEIGHT OF LOAD CELLS IN COUNTS** scrolls across the display and toggles with the current selection. Using the  and  buttons, enter the total full scale weight of the connected load cell(s) in counts, and then press .

Refer to the load cell manufacturer's test certificate.



- K** **___ ENTER MV/V FROM LOAD CELL** scrolls across the display and toggles with the current selection. Using the  and  buttons, enter the mV/V (or average mV/V) of the connected load cell(s). Press .

- L** **___ SET ZERO NOW ?** scrolls across the display and toggles with the current selection. Use the  and  buttons to select **NO** or **YES**, and then press .

*Selecting **YES** sets your zero position when the load cells are powered up and in position.*

- M** **MV/V** calibration is now complete. You will be directed out of the calibration menu to the operational display.



▶▶ ZERO (OFFSET) CALIBRATION ▶▶

- N** **__ _ ADJUST OFFSET** scrolls across the display and toggles with the currently selected zero value. Place a known weight on the weigh platform if required, and then use the  and  buttons to enter the desired value at this weight. Then press  to accept.



The offset will be automatically calculated to match the desired weight, and the scale factor will not be altered. Normally the weight would be removed from the weigh platform and the desired value would be zero.

- O** **ZERO** calibration is now complete. You will be directed out of the calibration menu to the operational display.

▶▶ E-CAL METHOD ▶▶

- P** **___ E_CAL ZERO OFFSET** scrolls across the display and toggles with the current selection. Use the  and  buttons to adjust the zero offset value, and then press .

*After a calibration has been performed, the **E_CAL ZERO OFFSET** value shows the resulting zero offset.*

- Q** **___ E_CAL SCALE FACTOR** scrolls across the display and toggles with the current selection. Use the  and  buttons to adjust the scale factor value, and then press .

*After a calibration has been performed, the **E_CAL SCALE FACTOR** value shows the resulting scale factor.*

- R** **E_CAL** calibration is now complete. You will be directed out of the calibration menu to the operational display.

5.4 Zero maintenance

▶▶ 5.4 Quick Access from operating mode ▶▶

Short-press **[F1]**. Use **[▲]** & **[▼]** to enter PIN. Press **[P]** 3 times.

A **___ ZERO MAINTENANCE** scrolls across the display and toggles with **SKIP**. Press **[P]** to skip to 5.5, or the **[▲]** button and then **[P]** to **ENTER** zero maintenance.

B **_ _ _ AUTO ZERO** scrolls across the display and toggles with the current auto zero selection. Use the **[▲]** and **[▼]** buttons to select **OFF** or **ON**, and press **[P]**.



*If **AUTO ZERO** mode is **ON**, the controller's offset will be automatically adjusted so that the instrument reads zero when it senses that the scale is not loaded. See Appendix C for more information.*

C





If you selected OFF in 5.4B:



Skip steps 5.4D-E and continue to 5.4F now.

D _ _ _ **CAPTURE BAND** scrolls across the display and toggles with the selected capture band. Adjust this value using the  and  buttons, and then press .

See Appendix C for more information.

E _ _ _ **MOTION BAND** scrolls across the display and toggles with the selected motion band. Adjust this value using the  and  buttons, and then press .

See Appendix C for more information.

F _ _ _ **ZERO BAND** scrolls across the display and toggles with the selected zero band. Adjust this value using the  and  buttons, and then press .

See Appendix C for more information.



5.5 Averaging

Your controller has input signal averaging, optimising stable measurement.

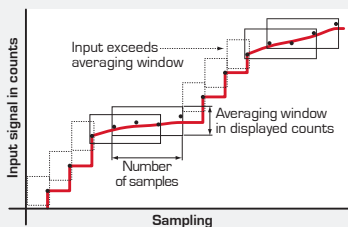

If the change in input exceeds the averaging window value it will not average, ensuring fast response when there are large differences between readings. (E.g. When a product is being dropped into a bag).



- A** **___ AVERAGING PARAMETERS** scrolls across the display and toggles with **SKIP**. Press **(P)** to skip to 5.6, or the **(▲)** button and then **(P)** to **ENTER** averaging parameters setup.

- B** **___ AVE SAMPLES** scrolls across the display and toggles with the currently selected averaging. Using the  and  buttons, alter the number of input samples that the controller will average, and then press .

Increasing the number of samples will stabilise measurement, but it will also slow down response rates. Typical value is 4.

- C** **___ AVE WINDOW** scrolls across the display and toggles with the currently selected averaging window value. Using the  and  buttons, alter the signal averaging window. Then press .

If your input signal contains large noise spikes, then you can increase the size of averaging window to ensure that these pulses are still averaged. However, increasing the averaging window too far will reduce the ability of the controller to respond quickly to real changes in input signal. A setting of 0 averages all reading. A typical value is 10% of your system capacity.

5.6 Analog output setup (if installed)



Some models do not have this option installed - these instructions are only relevant to controllers with analog output.

A **___ ANALOG OUTPUT SETUP** scrolls across display and toggles with **SKIP**. Press **[P]** to skip to 5.7, or the **[▲]** button and then **[P]** to **ENTER** analog output setup.

B **___ DATA SOURCE FOR ANALOG O/P** scrolls across the display and toggles with the currently selected data source. Using the **[▲]** and **[▼]** buttons, select: **NET/BATCH** or **LIVE**, and then press **[P]**.

NET/BATCH option is subject to the weighing mode selected in 5.2E. (NORMAL mode = NET option, BATCH mode = BATCH option.)

C **___ LOW SCALE VALUE FOR ANALOG O/P** scrolls across the display and toggles with the currently selected low scale value. Use the **[▲]** and **[▼]** buttons to set the low scale value. Then press **[P]**.

- D** **_ _ _ HIGH SCALE VALUE FOR ANALOG O/P** scrolls across the display and toggles with the currently selected high scale value. Use the  and  buttons to set the high scale value. Then press .

5.7 Serial setup (if installed)

Please note that some models do not have this option installed - these instructions are only relevant to controllers with serial output. Configuring the serial port on your GS100P (as specified below) will allow you to connect your controller to a PC or another device.



A _ _ _ **SERIAL SETUP** scrolls across the display and toggles with **SKIP**. Press **[P]** to skip to 5.8, or the **[▲]** button and then **[P]** to **ENTER** serial port setup.

B _ _ _ **SERIAL MODE** scrolls across the display and toggles with the currently selected serial mode. Using the **[▲]** and **[▼]** buttons, select either: **ASCII**, **MODBUS** (RTU) or **RNGR A** (Ranger A). Then press **[P]**.

ASCII is a simple protocol that allows connection to various PC configuration tools.

MODBUS is an industry standard RTU slave mode that allows connection to a wide range of devices, such as PC's or PLC's.

RNGR A is a continuous output, used to drive remote displays and other instruments in the Rinstrum™ range. (Ranger is a tradename belonging to Rinstrum Pty Ltd.)

- C** ___ **SERIAL DATA SOURCE** scrolls across the display and toggles with the currently selected data source. Using the  and  buttons, select: **NET/BATCH** or **LIVE**, and then press .



NET/BATCH option is subject to the weighing mode selected in 5.2E. (NORMAL mode = NET option, BATCH mode = BATCH option.)

D











If you selected ASCII or MODBUS in 5.7B:

Skip step 5.7E and continue to 5.7F now.

- E** ___ **RANGER OUTPUT MODE** scrolls across the display and toggles with the current selection. Use the  and  buttons to select either **CONT** (continuous) or **PULSED**. Then press .

In CONT (continuous) mode, the controller outputs a continuous stream of data. In PULSED mode, the controller outputs a single string when the print function is triggered from a user input button or pin (see 5.2H-K and Appendix B).

- F** _ _ _ **BAUD RATE** scrolls across the display and toggles with the current selection. Using the  and  buttons, select either: **300, 600, 1200, 2400, 4800, 9600, 19200** or **38400**. Then press .
- G** _ _ _ **PARITY** scrolls across the display and toggles with the currently selected parity. Using the  and  buttons, select: **NONE, ODD** or **EVEN**. Press .
- H** _ _ _ **SERIAL ADDRESS** scrolls across the display and toggles with the currently selected serial address. Use the  and  buttons to alter the serial address. Then press .

The serial address parameter is used to identify a particular device when it is used with other devices in a system. (It applies particularly to Modbus mode when used on an option 4 [RS485] serial network.) The serial address of the controller must be set to match the serial address defined in the master device.

For serial register tables, see Appendix D.

5.8 Edit calibration PIN

- A** **___ EDIT CAL PIN** scrolls across the display and toggles with **SKIP**. Press **P** to skip and return to the operational display, or the **▲** button and then **P** to **ENTER** and change your PIN number.
- B** **___ ENTER NEW CAL PIN** scrolls across the display and toggles with the current PIN (default 1). Using the **▲** and **▼** buttons, enter your new calibration PIN number. Then press **P** to **EXIT** and return to the operational display.

6 SETPOINT SETUP

Enter the setpoint setup mode by pressing and holding the **F2** button for 3 seconds.

6.1 Enter setpoint PIN

A **_ _ _ ENTER SP PIN** scrolls across the display and toggles with **0**. Use the **▲** and **▼** buttons to enter your security code (factory default 1). Then press **P**. If the correct PIN is entered then the setup is started at 6.2.

If an incorrect PIN number is entered, **_ _ _ ACCESS DENIED** scrolls across the display and it returns to the normal operating mode.

YOU WILL BE GIVEN THE OPPORTUNITY TO CHANGE YOUR PIN NUMBER AT THE END OF THIS SECTION (6.3). IF YOU HAVE FORGOTTEN YOUR PIN NUMBER, SEE SECTION 9.

6.2 Edit setpoints

A ___ **EDIT SETPOINT** scrolls across the display and toggles with **SKIP**. Press **[P]** to skip to 6.3, or use the **[▲]** and **[▼]** buttons to select a setpoint to edit: **SP 1**, **SP 2**, **SP 3** or **SP 4**. Then press **[P]**.

B ___ **SP VALUE** scrolls across the display and toggles with the display value at which the setpoint will activate. Adjust using the **[▲]** and **[▼]** buttons, and then press **[P]**.

C  **If you selected SP 1 in 6.2A:**

Skip step 6.2D and continue to 6.2E now.

D ___ **TRAIL SP1** scrolls across the display and toggles with the current selection. Use the **[▲]** and **[▼]** buttons to select **OFF** or **ON**, and then press **[P]**.

*If you choose **ON**, the selected setpoint will be automatically adjusted whenever SP 1 is changed, so that the 2 setpoints always trail each other by the same amount. Note: Set negative polarity if the setpoint operates before SP 1.*

E





If you selected **BATCH** in 5.2E **AND**
SP 1 or SP 2 in 6.2A:

SP 1 and **SP 2** are reserved for batch functions when your controller is in **batching mode**.



Skip steps 6.2F-J and continue to 6.2K now.

F

___ **SP SOURCE** scrolls across the display and toggles with the current setpoint source. Use the  and  buttons to select **NET/BATCH** or **LIVE**. Then press .

NET/BATCH option is subject to the weighing mode selected in 5.2E. (NORMAL mode = NET option, BATCH mode = BATCH option.)

G

_ _ _ **SP ACTIVATION** scrolls across the display and toggles with the current selection. Use the  and  buttons, select the relay activation to operate **ABOVE** or **BELOW** the setpoint value, and then press .

Select ABOVE for the relay to turn on above the setpoint value and off below it. Select BELOW for the relay to turn on below the setpoint value and off above it.

- H** **___ HYSTERESIS VALUE** scrolls across the display and toggles with the current selection. Adjust this value using the **▲** and **▼** buttons, and then press **P**.

This defines the separation band between setpoint activation and deactivation, and will operate as per the type [set in 6.2J.]

- I** **!** **If you set the HYSTERESIS VALUE to 0 in 6.2H:**

Skip step 6.2J and continue to 6.2K now.

- J** **___ HYSTERESIS TYPE** scrolls across the display and toggles with the current selection. Use the **▲** and **▼** buttons to select **ALARM** or **CNTRL**. Press **P**.

ALARM - Setpoint value setpoint activation point
Hysteresis value setpoint deactivation point

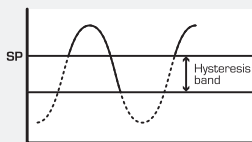

Energised Above

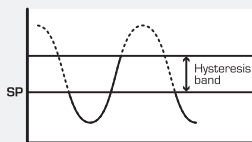

Energised Below

CNTRL - **Setpoint value** setpoint deactivation point
Hysteresis value setpoint reactivation point

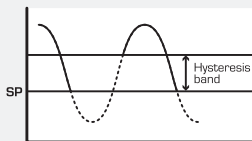

Energised Above

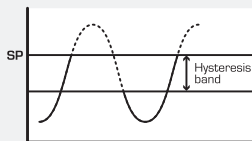

Energised Below

- K** **___ MAKE DELAY** scrolls across the display and toggles with the current selection. Use the and buttons to adjust the make delay value as required, and then press .

The make delay value defines the delay between setpoint activation and when the relay turns on. This value is in tenths of a second.

- L** **___ USER ACCESS?** scrolls across the display and toggles with the current access setting. Use the and buttons to select **NO** or **YES**, and then press .

*Choosing **YES** will allow the selected setpoint to be quick-edited via the button without entering a PIN (see section 8). User access can be independently configured for each setpoint.*

M _ _ _ **EDIT SETPOINT** scrolls across the display and toggles with **SKIP**. You are now back at 6.2A.

To edit another setpoint, follow the instructions from 6.2A-M again. If you do not wish to edit another setpoint, press **P** now to **SKIP** to 6.3.

6.3 Edit setpoint PIN

- A** **__ _ EDIT SP PIN** scrolls across the display and toggles with **SKIP**. Press **[P]** to skip and return to the operational display, or the **[▲]** button and then **[P]** to **ENTER**.
- B** **__ _ ENTER NEW SP PIN** scrolls across the display and toggles with the current PIN (default 1). Using the **[▲]** and **[▼]** buttons, enter your new setpoint entry PIN number. Then press **[P]** to save and **EXIT** to the operational display.

7 FACTORY ANALOG OUTPUT CAL



FACTORY ANALOG OUTPUT CALIBRATION IS PRECISELY SET BEFORE SHIPPING THIS INSTRUMENT. DO NOT ACCESS THIS FEATURE UNLESS INSTRUCTED BY THE MANUFACTURER. FOR ANALOG OUTPUT SCALING, SEE 5.6.

7.1 Factory calibration

- A** Start with your controller powered off. Power up the controller while holding the **F1** button.
- B** **___ ENTER CAL PIN** scrolls across the display and toggles with **0**. Use the **▲** and **▼** buttons to enter your security code (factory default 1). Then press **P**. If the correct PIN is entered, continue to 7.1C.



If an incorrect PIN is entered, **___ ACCESS DENIED** scrolls across and it returns to the main display.



See section 9 if you have forgotten your PIN.

C ___ **CALIBRATE ANALOG O/P?** scrolls across display and toggles with the current selection. Use the  and  buttons to select **YES** or **NO**, and then press .

D  **If you selected NO in 7.1C:**

Skip steps 7.1E-F and continue to 7.1G now.

E ___ **CAL LOW ANALOG O/P** scrolls across the display and toggles with the currently selected low scale value. Use the  and  buttons to set the low scale value. Then press .

F ___ **CAL HIGH ANALOG O/P** scrolls across the display and toggles with the currently selected high scale value. Use the  and  buttons to set the high scale value. Then press .

G Analog output calibration is now complete. You will be directed to the operational display.

8 SETPOINT EASY ACCESS

If none of the setpoints have their easy access option switched on, then this feature will be disabled and the **F2** button will not respond to a short button press (see 6.2L).



8.1 Setpoint easy access

- A** Begin by pressing the **F2** button for less than 3 seconds. The setpoint name (**SP 1**, **SP 2**, **SP 3** or **SP 4**) will appear on the display and toggle with the current setpoint value. Using the **▲** and **▼** buttons, adjust the selected value. Then press **P** to accept the new setpoint value.
- B** If any other setpoints have the direct access option enabled then the same process is repeated for the next setpoint. Pressing **P** for the last enabled setpoint will exit and return to the operational display.

9 RESET PIN NUMBERS

If you have forgotten your PIN number, follow the procedure below to reset both the calibration and setpoint setup PIN numbers to their factory default of 1.

9.1 Reset PIN numbers

- A** Press ,  and  at the same time. (This key combination can be difficult to execute and you may need several tries to get it right.)
- B** When successful, a factory identification text will scroll across the display, followed by: _ _ _ **ALL PIN NUMBERS RESET TO 1.**
- C** Reset the default PIN numbers if required by following the instructions in 5.8 (for setup and calibration) and 6.3 (for setpoint setup).

A

APPENDIX A
Tare & Batch Features

A.1

Tare

To access tare features, the controller's weighing mode must be set to **NORMAL** (see 5.2E). It is then possible to tare/reset tare from the **P** button or rear input pins (see 5.2H-K and Appendix B).

TARE - This feature 'zeroes' the display, and is usually used to deduct the weight of the container from the total weight, leaving only the weight of the product.

TARE RESET - This feature clears the current tare value and show the gross weight on the display.

A.2**Batch**

To access batching features, the controller's weighing mode must be set to **BATCH** (see 5.2E). It is then possible to batch/reset batch from the **P** button or rear input pins (see 5.2H-K and Appendix B).

BATCH - This function is used to display the live weight of the system but take regular 'batches' of product without continually changing the setpoint. When the **BATCH** function is activated the display will tare and SP 1 and SP 2 will turn on.

BATCH RESET - This feature resets the batch value to zero and halts any current batching operations.

BATCHING DIRECTION - This parameter is set in 5.2G, and is based on whether product is being added to or discharged from the weighing system. See overleaf for how to use positive/negative batching directions.

NORMAL BATCHING (POSITIVE DIRECTION) is when the weight increases as product is added to the weighing system. Set **BATCHING DIRECTION** to **POS** (see 5.2G).

*Eg. Setting a setpoint value of 50Kg for SP 1 and 5Kg for SP 2 and enabling batching mode (**POS** direction) will allow the user to fill a container to 50Kg with a potential speed change at 45Kg (50Kg - 5Kg).*

*The cycle is initiated when the **BATCH** function is triggered. The display will tare, and when 45Kg net weight is shown, SP 2 will drop out. If product continues to feed, at 50Kg SP1 will drop out, halting the fill.*

*If **FLASH GROSS** is enabled (see 5.2L) the gross weight will be displayed (Eg. Now 1050Kg, if the starting gross weight was 1000Kg). The user can then trigger the **BATCH** function again to call another 50kg batch.*

LOSS IN WEIGHT BATCHING (NEGATIVE DIRECTION) is when the weight decreases as product is removed from the weighing system. Set **BATCHING DIRECTION** to **NEG** (see 5.2G).

*Eg. Setting a setpoint value of 50Kg for SP 1 and 5Kg for SP 2 and enabling batching mode (**NEG** direction) will allow the user to fill a container to 50Kg with a potential speed change at 45Kg (50Kg - 5Kg).*

The cycle is initiated when the **BATCH** function is triggered. The display will tare, and when 45Kg net weight is discharged, SP 2 will drop out. If product continues to be discharged, at 50Kg SP1 will drop out, halting the product flow.

If **FLASH GROSS** is enabled (see 5.2L) the gross weight will be displayed (Eg. Now 950Kg, if the starting gross weight was 1000Kg). The user can then trigger the **BATCH** function again to call another 50kg batch.

In this mode if there is not enough product to drop a batch then the instrument will advise the operator by showing the message **LOW PRODUCT**.

If **gross > SP1**, the batch value is reset to zero and the display flashes **BATCH**. SP1 is turned on (and SP2 if set up). If **gross < SP1**, batching is not started.

B

APPENDIX B
Input Functions

This section provides information on user programmable functions that are accessible from the **P** button and rear pins (see 5.2H-K). Refer to the key for activation times.

Please note that availability of the **TARE/BATCH** feature is subject to your selection in 5.2E.

KEY

P	Continuous press	→	Continuous pin activation
P ^{1/2}	Short press (1/2 sec)	→ ^{1/2}	Short pin activation (1/2 sec)
P ²⁺	Long press (2+ sec)	→ ²⁺	Long pin activation (2+ sec)

HOLD	P →→	Freezes the current display value.
LOCK	→	Locks the control panel.
TARE	P ^{1/2} →→ ^{1/2}	Tares display value (flashes TARE).
	P ²⁺ →→ ²⁺	Resets tare to zero (flashes TR RST and then shows gross).

BATCH $\boxed{P}^{1/2} \leftrightarrow 1/2$ Performs a batch operation.

If a batch is already in progress, no function will be performed.

*If you have just powered up following a power loss during batching, then activating this function will cause the controller to **RESUME** without resetting the batch value.*

See Appendix A for more information.

$\boxed{P}^{2+} \leftrightarrow 2+$ Resets the batch value to zero and flashes **BT RST**. Any current batching operations will be halted.

ZERO $\boxed{P}^{1/2} \leftrightarrow 1/2$ Zeroes the weight if the zero offset [i.e. the difference between the current no load weight and the calibration no load value] is within the **ZERO BAND**.

*If the offset is less than the limit set in **ZERO BAND** (see 5.4F), the zero value is updated and the display flashes **ZERO**.*

*If the offset is greater than the limit set in **ZERO BAND** (see 5.4F), the zero value is not updated and the display scrolls **OUTSIDE OF ZERO BAND!***

See Appendix C for more information.

$\boxed{P}^{2+} \leftrightarrow 2+$ Resets the zero offset value to the original calibration offset value. Display flashes **RS ZER** and then shows gross.

PEAK	$\boxed{P}^{1/2}$	Displays the peak value for 2 seconds.
	\boxed{P}^{2+}	Sets the peak value to the current input value. Display flashes PK RST .
	\rightarrow	Displays the peak value continuously.
PK RST	$\boxed{P} \rightarrow$	Sets the peak value to the current input value. Display flashes PK RST .
	$\boxed{P} \rightarrow$	Sends a single Ranger A output string. <i>SERIAL MODE must be set to RNGR A (see 5.7B), and RANGER OUTPUT MODE must be set to PULSED (see 5.7E).</i>

C

APPENDIX C
Zero Maintenance

The zero maintenance feature is used to automatically compensate for slow drift in loadcell output due to factors such as temperature change, rain and dust accumulation over time. The controller display will zero automatically, provided that changes to the loadcell remain within the user specified **CAPTURE BAND**, **MOTION BAND** and **ZERO BAND** parameters (see 5.4D-F).

CAPTURE BAND (5.4D) - This is the maximum number of display counts that the controller will automatically zero within. The **CAPTURE BAND** is referenced to the current zero value. If the input value on the load cell is not within the **CAPTURE BAND** setting then the controller displays the current loadcell value and does not zero.

***CAPTURE BAND** can be set from 1 to 254 counts, and should always be set to less than the smallest weight to be measured. Setting the **CAPTURE BAND** to 0 will turn the auto zero feature off.*

MOTION BAND (5.4E) - This provides a rate of change limit setting, to determine the number of counts/second allowed within the **CAPTURE BAND**. If the count change is within the **CAPTURE BAND**, but the speed of the count change is more than the selected **MOTION BAND**, then the controller displays the current loadcell value and does not zero.

*The **MOTION BAND** can be set from 0 to 255 counts. Typical value is 1 or 2 counts/sec.*

ZERO BAND (5.4F) - This provides a limit for the number of counts of zero offset allowed to accumulate, relative to the calibrated zero setting. If the accumulated zero offset becomes greater than this window, then the controller displays the current loadcell value and does not zero.

*The suggested limit for the **ZERO BAND** is 2% of the calibrated span. If the controller fails to zero, check for mechanical or electrical faults.*

D

APPENDIX D

Serial Register Tables

MODBUS REGISTERS - These are all holding registers and should be accessed via function codes 3 and 6. Register addresses are displayed in the Modicon™ addressing format. i.e. Register 65=40065 [subtract 1 for direct addressing].

16-BIT UNSIGNED		32-BIT SIGNED (2x16-bit)	
Address	Function	LSW / MSW	Function
40001	Alarm status*	40515 / 40516	Tared/Batch weight (net)
40065	Hysteresis SP1	40517 / 40518	mV
40071	Make delay SP1	40521 / 40522	Live weight (gross)
40066	Hysteresis SP2	40529 / 40530	Tare value
40072	Make delay SP2	40525 / 40526	Peak
40067	Hysteresis SP3	40527 / 40528	Valley
40073	Make delay SP3	40535 / 40536	Setpoint 1
40068	Hysteresis SP4	40537 / 40538	Setpoint 2
40074	Make delay SP4	40539 / 40540	Setpoint 3
*Bit 0=SP1, Bit 1=SP2, Bit 2 =SP3, Bit 3=SP4		40541 / 40542	Setpoint 4
		40587 / 40588	D/A scale low value
		40591 / 40592	D/A scale high value

ASCII REGISTERS

<i>16-BIT UNSIGNED</i>	
<i>Address</i>	<i>Function</i>
1	Alarm status*
65	Hysteresis SP1
71	Make delay SP1
66	Hysteresis SP2
72	Make delay SP2
67	Hysteresis SP3
73	Make delay SP3
68	Hysteresis SP4
74	Make delay SP4
* Bit 0=SP1, Bit 1=SP2, Bit 2=SP3, Bit 3=SP4	

<i>32-BIT SIGNED</i>	
<i>Address</i>	<i>Function</i>
3	Tared/Batch weight (net)
4	mV
39	Live weight (gross)
16	Tare value
12	Peak
13	Valley
6	Setpoint 1
7	Setpoint 2
8	Setpoint 3
9	Setpoint 4
34	D/A scale low value
36	D/A scale high value

RANGER A - This allows the controller to drive a remote display from the Rinstrum range. The following shows the output string format when Ranger A output is selected:

<Start> <Sign> <Output Value> <Status> <End>

<i>STRING CHARACTER(S)</i>	
<Start>	STX character (ASCII 02)
<Sign>	Output value sign (space for + and dash for -)
<Output Value>	Seven character ASCII string containing the current output value and decimal point. <i>(If there is no decimal point, then the first character is a space. Leading zero blanking applies.)</i>
<Status>	Single character output value status: U=Under, O=Over, E=Error
<End>	ETX character (ASCII 03)



Gedge Systems

488 Church Street, Richmond,
VIC 3121, Australia

Ph: +61 (3) 9429-8396

Fax: +61 (3) 9429-8097

Web: www.gedgesystems.com.au

Email: info@gedgesystems.com.au



GS100P

**DOCUMENT REVISION CODE:
GS100P-MAN-09-V.02**