



GS-KMT Load Cells



# GS-KMT Model GK2107S Stainless Steel 25kg to 5,000kg Welded Sealed IP68\* Shearbeam Load Cell



## KEY FEATURES

- Hermetically Sealed IP68\* Rating
- Laser\* Welded seal construction.
- High Grade Stainless Steel.
- Matched outputs make corner adjustments un-necessary in most applications.
- Load Cells 100% tested to guarantee load & thermal specifications met or exceeded.
- Integral mounting step reduces need for spacer plate & improves mounting.
- High Accuracy 0.02% Combined Error
- Wide range of "purpose designed" Stainless Steel feet, fittings and mounts.
- Popular Capacities - 25kg to 5,000kg.
- M12/16/18 Mounting threads allow the use of Rugged Feet and Fittings.
- 12.5mm and 21mm Large Mounting Holes allow the use of Strong hold down bolts.

## APPLICATIONS

- All Floor Scales.
- Batch weighing.
- Hopper filling and level control.
- Food and Chemical Industry.
- Bagging and Filling Machines.
- Inventory Control - by weight.
- Shipping Scales.
- Cattle Scales.
- All Agricultural Applications.

## Specifications

|                                   |                |
|-----------------------------------|----------------|
| Capacity . . . . .                | 25kg - 5,000kg |
| Safe Service Load . . . . .       | 100% Capacity  |
| Safe Overload . . . . .           | 150% Capacity  |
| Ultimate Load . . . . .           | 300% Capacity  |
| Safe Side Load . . . . .          | 100% Capacity  |
| Full Load Output . . . . .        | 2mV/V ± 0.10%  |
| Combined Error . . . . .          | <0.02% FS      |
| Non Repeatability . . . . .       | <0.01% FS      |
| Creep (30min) . . . . .           | <0.02% FS      |
| Zero Balance . . . . .            | <2% FS         |
| Span temperature effect . . . . . | <30ppm/°C      |
| Zero temperature effect . . . . . | <20ppm/°C      |
| Compensated Range . . . . .       | -10°C to +40°C |
| Operating Range . . . . .         | -18°C to +65°C |

|  |                   |
|--|-------------------|
| *Environmental Protection Rating . . . . . | IP68 500-5000kg   |
| *Environmental Protection Rating . . . . . | IP67 25-250kg     |
| Material . . . . .                         | Stainless Steel   |
| *Construction 500kg-5,000kg . . . . .      | Laser Welded Seal |
| *Construction 25kg-250kg . . . . .         | Bonded Seal       |
| Input Resistance . . . . .                 | 385Ω ± 5Ω         |
| Output Resistance . . . . .                | 385Ω ± 3Ω         |
| Insulation Resistance . . . . .            | >3,000MΩ          |

Excitation (Recommended) . . . . . 5VDC to 12VDC  
 Excitation (Maximum) . . . . . 15VDC

Cable type ... 6mm OD 6 core screened.  
 Cable length 6 metres  
 Cable Entry....Gland & Cable Strain Relief Spring.

# Description & Ordering GK2107S

**Description:-** The Gedge Systems-KMT Mechtronix GK2107S Shear Beam Load Cell has been designed from the ground up to offer class leading long term performance in harsh environments.

It is part of a very large range of High Quality Load Cells brought to Australia & New Zealand by Joint Venture Partners Gedge Systems & KMT Mechtronix.

The GK2107S Shear Beam is ruggedly built of fine quality Stainless Steel. It has generously sized attachment threads and through holes to allow the use of strong fixing bolts and ruggedly built attachments and mounts

The GK2107S Welded Seal Construction assures users of its IP68 Environment Protection Rating and provides a safe environment for the long term protection of its internal construction. (25kg-250kg IP67 Bonded Seal)

This is a Load Cell for Weighing now and into the Future.

**Ordering:-**

- GK2107S0.2** 25kg Stainless Steel IP67 Shear Beam
- GK2107S0.5** 50kg Stainless Steel IP67 Shear Beam
- GK2107S1.0** 100kg Stainless Steel IP67 Shear Beam
- GK2107S2.5** 250kg Stainless Steel IP67 Shear Beam
- GK2107S-05** 500kg Stainless Steel IP68 Shear Beam
- GK2107S-10** 1,000kg Stainless Steel IP68 Shear Beam
- GK2107S-20** 2,000kg Stainless Steel IP68 Shear Beam
- GK2107S-30** 3,000kg Stainless Steel IP68 Shear Beam
- GK2107S-50** 5,000kg Stainless Steel IP68 Shear Beam

**Accessories.** A wide range of accessories is available for all GS-KMT Load Cells. They make using the GK2107S in your application easier and more cost effective while at the same time meeting your requirements for strength and durability. Refer to the GS-KMT Shear Beam Load Cell Accessories Brochure for full details.

**GEDGE SYSTEMS - Since 1978 Australia's Leading Manufacturer of High Accuracy Weighing Electronics now bringing you Superior Quality GS-KMT Load Cells**

## Dimensions GK2107S

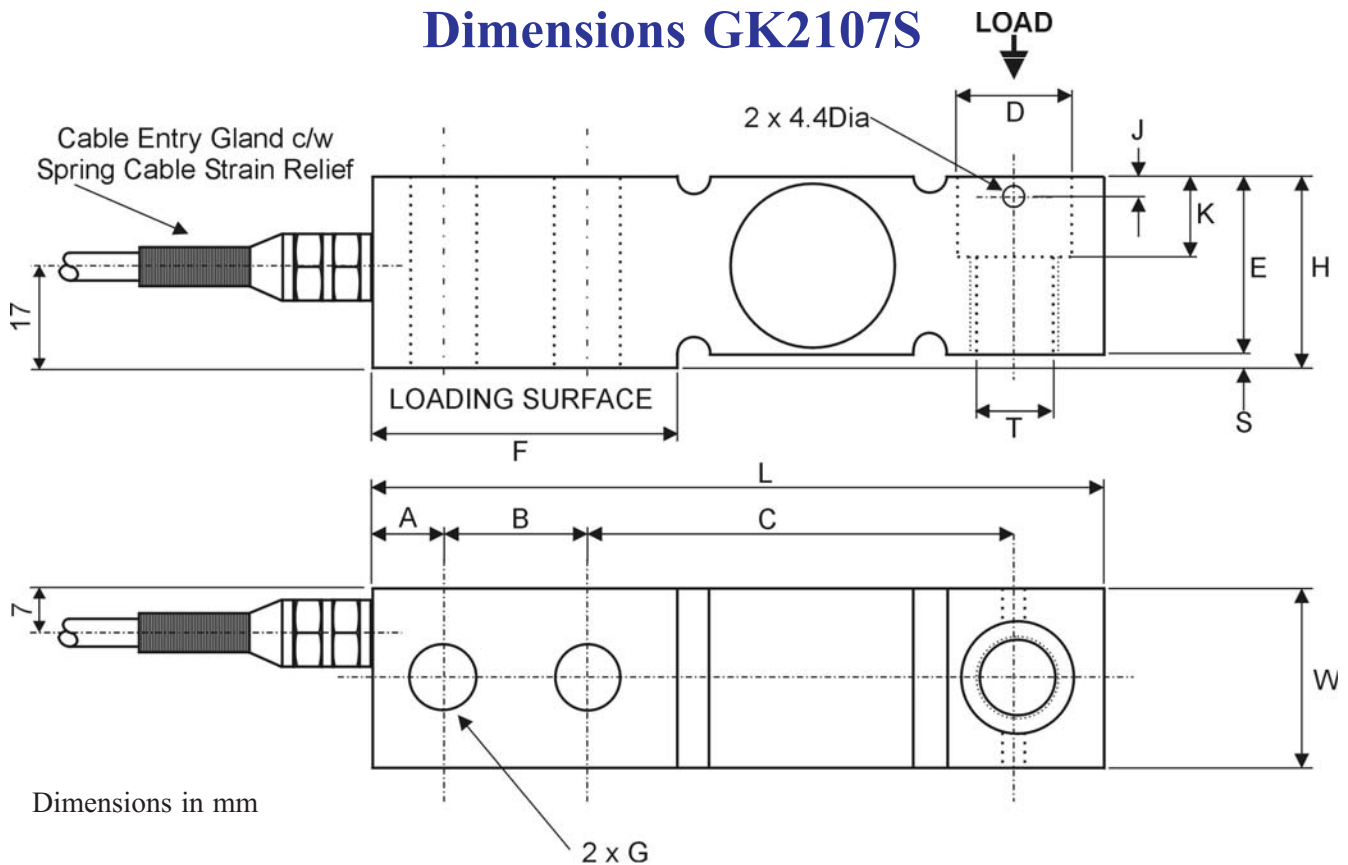

Dimensions in mm

| Cap kg    | A    | B    | C    | D     | E    | F  | G     | H    | J   | K    | L     | S   | T        | W    |
|-----------|------|------|------|-------|------|----|-------|------|-----|------|-------|-----|----------|------|
| 25-250    | 12.7 | 25.4 | 76.2 | ∅12.6 | 31.8 | 54 | ∅12.5 | 33.8 | 3.5 | 12.2 | 130.0 | 2.0 | M12x1.75 | 31.8 |
| 500-3,000 | 12.7 | 25.4 | 76.2 | ∅20   | 31.8 | 54 | ∅12.5 | 33.8 | 3.5 | 14.2 | 130.0 | 2.0 | M16x2    | 31.8 |
| 5,000     | 19.1 | 38.1 | 95.3 | ∅20   | 38.1 | 77 | ∅21.0 | 41.0 | 4.5 | 16.0 | 171.5 | 2.9 | M18x1.5  | 38.1 |

© Copyright 2008 GS Systems Pty Ltd ABN 18 737 137 544 - GS Standard 1 year Warranty - Specification subject to change without notice.